

# MK-EHA5260

1080p Full HD Stainless Steel  
Outdoor Dome Camera

**eZ.HD**



## Features

- Supports 1080p / 960H analog signal output
- Features Sony 1080p CMOS sensor with selectable 3.6mm/6mm/8mm lens
- Marine Grade Stainless Steel (AISI 316) housing can withstand harsh and corrosive environment
- Extended IR range of up to 30m / 98ft. with 12 LEDs (depends on scene IR reflectivity)
- D-WDR to improve the visibility under high contrast scene
- 3D-Noise Reduction ensures less blurry moving subjects, vivid and high SN ratio images even under low light environments
- Supports UTC function: Control camera OSD settings directly from DVR end
- Suitable for arsenal, chemical plant, refinery, high corrosive environment, salt environment

## Dimensions

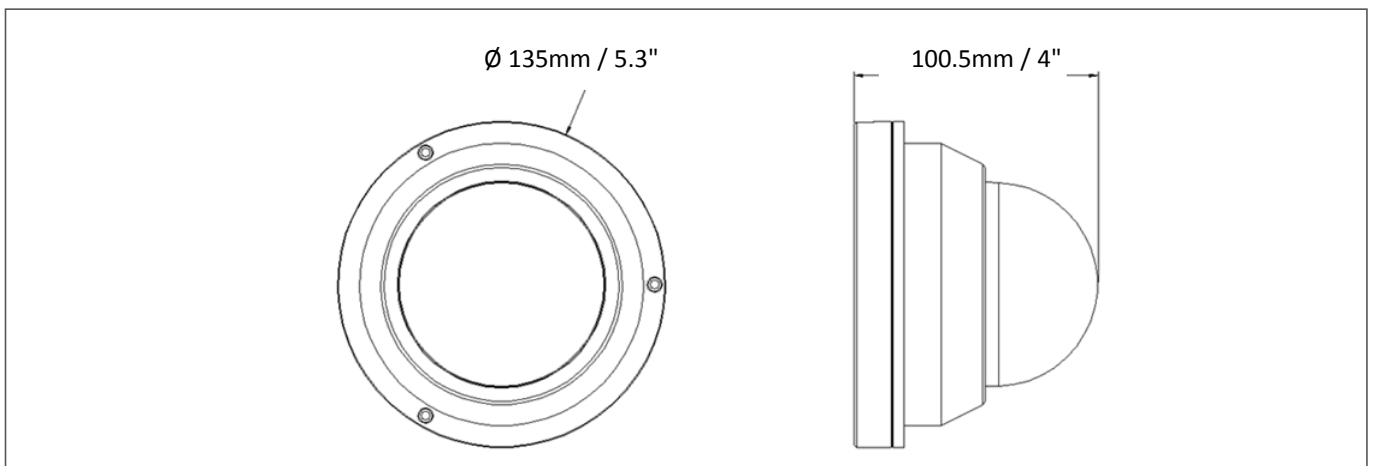

\*Information contained in this document is subject to change without notice.

# Specifications

Model No.		MK-EHA5260	
Pickup Device	Sony 1080p CMOS	S/N Ratio	≥41dB
Video Format	NTSC / PAL (switchable via OSD)	OSD Languages	English / Simplified Chinese / Traditional Chinese / German / French / Italian / Spanish / Polish / Russian / Portuguese / Netherlands / Turkish
Effective Pixels	1920 (H) x 1080 (V)	DNR	2DNR / 3DNR / Off
Scanning System	Progressive Scan	Defog	Off / Auto
Sensitivity	0 Lux with IR On	D-WDR	On / Off / Auto
Electronic Shutter	Auto / Manual (x30 ~ 1/50,000) / FLK	Sens-up	Off / Auto (x2 ~ x30)
Gamma Correction	0.45	Mirror	Off / Mirror / V-Flip / Rotate
Lens Type	3.6mm/6mm/8mm fixed lens	Motion Detection	Off / On for 4 selectable zones
FOV (H x V x D)	N/A	Privacy Mask	Off / On for 4 selectable zones
BLC	Off / BLC / HS BLC Selectable	Environmental	IP68 Weather Resistant
AGC	0 ~ 15 Levels	Power Source	12VDC
White Balance	ATW / AWC-SET / Indoor / Outdoor / Manual / AWB	Power Consumption	3W (Max.)
Sync. Mode	Internal	Operating Temperature	-10°C ~ 50°C / -14°F ~ 122°F
Day / Night	Ext, Auto, Color, B/W	Humidity	0% ~ 90% not condensing
UTC Function	Supported	Dimensions (Φ) x (H)	135 x 100.5mm / 5.3" x 4"
IR LEDES	12 Units	Weight	2300g / 5.07lb
IR Distance	Up to 30m / 98ft. (depends on scene IR reflectivity)	Certificates	CE, FCC, RoHS